

KAWAI

**P R O D U C T S
C A T A L O G U E**



G R A N D P I A N O S



U P R I G H T P I A N O S



D I G I T A L P I A N O S

E N G L I S H / E S P A Ñ O L

The Art of the Piano

A grand piano instrument consists of over nine-thousand precision parts, crafted from fine woods, rigid metals, soft fibres, compound resins, and countless other natural and man-made materials. Simply assembling each component into the mere form of a grand piano is, in itself, an immense undertaking.

Yet the process of crafting such raw materials into a precision instrument, that is capable of expressing the emotional subtleties of the human soul, an instrument that illuminates grand concert halls, leaving audiences enchanted, and an instrument that truly sings with a unique voice all of its own... such a process requires a passionate quest for excellence, with generations of knowledge and expertise.

At Kawai, this process is fittingly regarded as *the art of the piano*.



El Arte del Piano

Un piano de cola consiste en más de nueve mil piezas de precisión, hechas a mano con maderas finas, metales rígidos, fibras suaves, compuestos de resina, y otros incontables materiales naturales y artificiales. Simplemente montar cada componente para formar un piano de cola es, en sí mismo, una empresa inmensa.

El proceso de elaboración a mano y transposición de dichos materiales en un instrumento de precisión, capaz de expresar las delicadas emociones del alma, un instrumento que ilumina salones de conciertos magníficos, encantando a las audiencias, y un instrumento que canta verdaderamente con una voz única...tal proceso requiere una búsqueda apasionada por la excelencia, con generaciones de conocimiento y de maestría.

En Kawai, este proceso se considera como el arte del piano.



GRAND PIANOS

GX Series

The GX Series is a unified line of six superb instruments, offering one consistent level of exceptional grand piano performance. Each GX Grand Piano is the result of uncompromising craftsmanship, honed by generations of experience and refinement.

La serie GX es una línea unificada de seis instrumentos magníficos, ofreciendo un nivel constante de rendimiento excepcional del piano de cola. Cada piano de cola GX es el resultado de artesanía absoluta, perfeccionada por generaciones de experiencia y de refinamiento.

Superb tone is the first hallmark of every Kawai piano, with countless hours of research and development paying dividends in perfecting the GX Series' exceptional sound. Yet, playing the piano is as much a tactile experience as it is auditory; professional pianists demand greater speed, control, and power from every key stroke. Fortunately, consistent, ultra-responsive touch remains a Kawai speciality, with continued innovation providing a truly unparalleled playing experience.

El tono espléndido es el primer sello de cada piano de Kawai, con horas incontables de investigación y de desarrollo para perfeccionar el sonido excepcional de la serie GX. Sin embargo, tocar el piano es tanto una experiencia táctil como auditiva; los pianistas profesionales exigen mayor velocidad, control y fuerza en cada pulsación. Afortunadamente, la pulsación constante y ultra-respuesta sigue siendo una especialidad de Kawai, con la innovación duradera, y a la vez una experiencia de interpretación verdaderamente inigualable.

GX-7

229 (L) x 157 (W) x 102 (H) cm



GX-3

188 (L) x 152 (W) x 102 (H) cm



GX-6

214 (L) x 154 (W) x 102 (H) cm



GX-2

180 (L) x 152 (W) x 102 (H) cm



GX-5

200 (L) x 153 (W) x 102 (H) cm



GX-1

166 (L) x 150 (W) x 102 (H) cm



BABY GRAND PIANOS

GE & GM Series

The GE and GM models offer the meticulous attention to detail and quality of larger Kawai grand pianos, within a petite cabinet size – combining stylish elegance with outstanding performance, for an impressive addition to a family home or studio.

Los modelos GE y GM ofrecen en tamaños más pequeños la misma calidad de los pianos gran cola de Kawai. Combinan estilo y elegancia con un rendimiento excepcional, para una adquisición impresionante tanto en el hogar como en un estudio.



GE-30

164 (L) x 150 (W) x 102 (H) cm



GE-20

154 (L) x 150 (W) x 102 (H) cm



GM-12

150 (L) x 150 (W) x 102 (H) cm



GM-10

150 (L) x 150 (W) x 102 (H) cm



GE-30, GE-20 and GM-12 atrx models also available, depending on market area.
Los modelos GE-30, GE-20 y GM-12 atrx también están en función de área de mercado.

CONSERVATORY GRAND PIANOS

RXc Series

The Kawai RX Conservatory grand pianos have been specially crafted for school and institutional use. Their intelligent design and expositional performance will exceed the most demanding requirements of any educational or institutional environment.

Los pianos de cola de Conservatorio Kawai RX han sido especialmente diseñados para la escuela y el uso institucional. Gracias a su diseño inteligente y un rendimiento exposicional, se superan los requisitos más exigentes de cualquier entorno educativo o institucional.



RX-3c

186 (L) x 152 (W) x 102 (H) cm



RX-2c

178 (L) x 152 (W) x 102 (H) cm



SPECIFICATIONS

		GX-7	GX-6	GX-5	GX-3	GX-2	GX-1	GE-30	GE-20	GM-12	GM-10	RX-3c	RX-2c
Size	Height	102 cm	102 cm	102 cm	102 cm	102 cm	102 cm	102 cm	102 cm	102 cm	102 cm	102 cm	102 cm
	Width	157 cm	154 cm	153 cm	152 cm	152 cm	150 cm	150 cm	150 cm	150 cm	150 cm	150 cm	152 cm
	Length	229 cm	214 cm	200 cm	188 cm	180 cm	166 cm	164 cm	154 cm	150 cm	150 cm	150 cm	186 cm
	Weight	400 kg	382 kg	351 kg	334 kg	324 kg	314 kg	302 kg	290 kg	272 kg	272 kg	272 kg	326 kg
Soundboard	Material	Spruce	Spruce	Spruce	Spruce	Spruce	Spruce	Spruce	Spruce	Spruce	Spruce	Spruce	Spruce
	Area	1.70 m ²	1.60 m ²	1.41 m ²	1.33 m ²	1.23 m ²	1.17 m ²	1.17 m ²	1.03 m ²	0.98 m ²	0.98 m ²	1.33 m ²	1.23 m ²
No. of Beams		4	4	4	4	3	3	3	3	2	2	4	3
Millennium III Action		•	•	•	•	•	•	•	•	•	-	•	•
Hammers	Material	Mahogany	Mahogany	Mahogany	Mahogany	Mahogany	Mahogany	Maple	Maple	Maple	Maple	Mahogany	Mahogany
	Felting	Underfelted	Underfelted	Underfelted	Underfelted	Underfelted	Underfelted	Underfelted	Underfelted	Underfelted	Underfelted	Underfelted	Underfelted
Key Surfaces		Neotex	Neotex	Neotex	Neotex	Neotex	Neotex	Neotex	Neotex	Acrylic/Phenol	Acrylic/Phenol	Neotex	Neotex
Duplex Scale		•	•	•	•	•	•	•	•	-	-	•	•
Agraffes		1" - 54 th key	1" - 54 th key	1" - 54 th key	1" - 54 th key	1" - 54 th key	1" - 46 th key	1" - 46 th key	1" - 46 th key	-	-	1" - 54 th key	1" - 54 th key
'Soft Fall' Fallboard		•	•	•	•	•	•	•	•	•	-	•	•
Caster Configuration		Double, Brass	Double, Brass	Single, Brass	Single, Brass	Single, Brass	Single, Brass	Single, Brass	Single, Brass	Single, Brass	Single, Brass	Single, Brass	Single, Brass
Fallboard Lock		•	•	•	•	•	•	-	-	-	-	•	•

UPRIGHT PIANOS

K Series

K Series upright pianos offer a level of tonal quality and performance to rival many grand pianos. With sturdy construction for years of reliable service, these instruments are an excellent choice for auditoriums, schools, and other institutional settings.

Los pianos de la serie K ofrecen un nivel de calidad tonal y de funcionamiento para competir con muchos pianos de cola. La construcción robusta asegura años de servicio fiable. Estos instrumentos son una opción excelente para los auditorios, las escuelas y otros escenarios institucionales.

In 1971 Kawai revolutionised piano technology by introducing ABS parts within the fine workings of the piano action. This rigid, atmospherically stable compound material, addressed many of the problems associated with wooden components, such as breakages under continual high stress, and shrinking and swelling due to changes in climate. The Millennium III Upright Action utilises stronger ABS Carbon parts, allowing Kawai engineers to further optimise key repetition and response speed.

En 1971 Kawai revolucionó la tecnología del piano con la introducción de piezas ABS dentro de los selectos engranajes del mecanismo del piano. Este material compuesto, rígido y atmosféricamente estable, solucionó muchos de los problemas que están vinculados con piezas de madera, como roturas por tensiones altas constantes, y cambios de oscilación por cambios del clima. El Millennium III Upright Action utiliza piezas de carbón ABS más fuertes, permitiendo que los ingenieros de Kawai optimicen aún más la repetición de las teclas y la rapidez de reacción.



K-800

134 (H) x 153 (W) x 65 (D) cm



E/P



K-700

130 (H) x 150 (W) x 62 (D) cm



E/P



K-400

122 (H) x 149 (W) x 61 (D) cm



E/P



K-300

122 (H) x 149 (W) x 61 (D) cm



E/P E/S WH/P MH/P MH/S



K-600

134 (H) x 153 (W) x 65 (D) cm



E/P



K-500

130 (H) x 150 (W) x 62 (D) cm



E/P E/S SM/P



K-200

114 (H) x 149 (W) x 57 (D) cm



E/P E/S WH/P MH/P MH/S



K-15

110 (H) x 149 (W) x 59 (D) cm



E/P WH/P MH/P

HYBRID PIANOS

AnyTimeX2

AnyTimeX2 instruments incorporate an acoustic muting feature with powerful digital audio components, allowing pianists to continue enjoying the distinctive feeling of a traditional piano more discreetly, without disturbing family members or neighbours.

Los instrumentos de AnyTimeX2 incorporan un característico silenciador acústico con potentes componentes digitales, que permiten que los pianistas sigan disfrutando más discretamente de la sensación distintiva de un piano tradicional, sin molestar en su entorno.



GX-2 ATX2



180 (L) x 152 (W) x 102 (H) cm



K-500 ATX2

130 (H) x 150 (W) x 62 (D) cm



SPECIFICATIONS

		K-800	K-700	K-600	K-500	K-400	K-300	K-200	K-15
Size	Height	134 cm	130 cm	134 cm	130 cm	122 cm	122 cm	114 cm	110 cm
	Width	153 cm	150 cm	153 cm	150 cm	149 cm	149 cm	149 cm	149 cm
	Depth	65 cm	62 cm	65 cm	62 cm	61 cm	61 cm	57 cm	59 cm
	Weight	284 kg	241 kg	280 kg	238 kg	230 kg	227 kg	208 kg	193 kg
Soundboard	Material	Solid Spruce	Solid Spruce	Solid Spruce	Solid Spruce	Solid Spruce	Solid Spruce	Solid Spruce	Solid Spruce
	Area	1.52 m ²	1.45 m ²	1.52 m ²	1.45 m ²	1.39 m ²	1.39 m ²	1.34 m ²	1.31 m ²
Back Posts		6	5	6	5	5	5	4	4
Millennium III Action		•	•	•	•	•	•	•	-
Hammers	Material	Mahogany	Mahogany	Mahogany	Mahogany	Mahogany	Mahogany	Mahogany	Maple / Sycamore
	Felting	All Underfelted	All Underfelted	All Underfelted	All Underfelted	All Underfelted	All Underfelted	All Underfelted	Single felted
Key Surfaces		Neotex	Neotex	Neotex	Neotex	Acrylic/Phenol	Acrylic / Phenol	Acrylic/Phenol	Acrylic / Phenol
Tuning Pins		Nickel Plated	Nickel Plated	Nickel Plated	Nickel Plated	Nickel Plated	Nickel Plated	Nickel Plated	Nickel
Duplex Scale		Fore / Back	Fore	Fore / Back	Fore	-	-	-	-
Agraffes		1" - 51" key	-	1" - 51" key	-	-	-	-	-
Front Caster Configuration		Double, Brass	Double, Brass	Double, Brass	Double, Brass	Double, Brass	Double, Brass	Single, Brass	-
Lock		•	•	•	•	-	-	-	-

ATX2	GX-2* / GE-30 / GE-20 / GM-12	K-500* / K-300 / K-200	K-15
Sound Source	Harmonic Imaging™ XL (HI-XL), 88-key piano sampling		Progressive Harmonic Imaging™ (PHI), 88-key piano sampling
Polyphony	max. 256 notes		max. 192 notes
Internal Sounds	27 voices		16 voices
Display	128 x 64 pixel LCD with backlight		-
Reverb	Types: Room, Lounge, Small Hall, Concert Hall, Live Hall, Cathedral Parameters: Reverb Depth, Reverb Time		Types: Room, Lounge, Small Hall, Concert Hall, Live Hall, Cathedral Parameters: x
Metronome	1/4, 2/4, 3/4, 4/4, 5/4, 3/8, 6/8, 7/8, 9/8, 12/8 + 100 drum rhythms		1/4, 2/4, 3/4, 4/4
Recorder	10 song, 2 track recorder – approximately 90,000 note memory capacity		-
USB Functions	Play & Record MP3/WAV/MID, Load & Save Internal Song/User Memory, Save SMF Song, Rename File, Delete File, Format USB, Convert Song to Audio, Overdub Audio		-
Lesson Function	Finger exercises + Alfred or Burgmüller, Czerny, Beyer, and Bach lesson books **		-
Virtual Technician	Voicing, Damper Resonance/Noise, String Resonance, Key-off Effect (incl. Key-off Release), Fall-back Noise, Hammer Delay, Topboard, Decay Time, Soft Pedal Depth, User Touch Curve, Temperament, Key of Temperament, Stretch Tuning, Tuning, User Tuning, User Key Volume, Half-Pedal Adjust, Minimum Touch		-
Other Features	Dual/Split/Four Hands, Balance Adjust, Key/Song Transpose, Tone Control (incl. User EQ), Speaker*/Phones/Line Out Volume, Audio Recorder Gain, Wall EQ*, Damper Hold, LCD Contrast, User Memory, Factory Reset, Lower Octave Shift, Lower Pedal On/Off, Layer Octave Shift, Layer Dynamics, MIDI Channel, Send PGM#, Local Control, Transmit PGM#, Multi-timbral Mode, Channel Mute, Auto Power Off		Damper Resonance, Tuning, Transpose, MIDI Channel, Local Control, Auto Power Off
Jacks	MIDI (IN/OUT), USB (to Device), LINE IN, LINE OUT, Headphones x 2		MIDI (IN/OUT), LINE OUT, Headphones x 2

*ATX2 model with soundboard speaker also available. / Modelo de ATX2 con altavoz en la caja armónica también disponible. ** Depending on market area. / En función de área de mercado. Headphones included with all AnyTimeX2 instruments. / Auriculares incluidos con todos instrumentos AnyTimeX2.

ACOUSTIC PIANO FINISHES



E / P

Ebony Polish
Ebano pulido



E / S

Ebony Satin
Ebano satinado



WH / P

White Polish
Blanco pulido

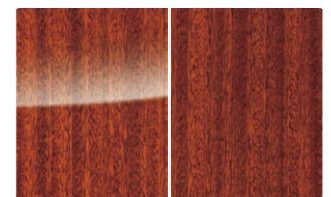

SBM / P SBM / S

Sapele Brown Mahogany
Marrón Caoba Sapeli



MH / P

Mahogany Polish
Caoba pulido

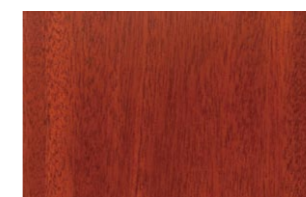

MH / S

Mahogany Satin
Caoba satinado



SM / P

Sapele Mahogany Polish
Caoba Sapeli pulido

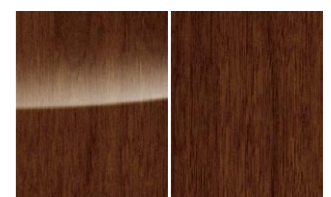

BW / P BW / S

Brown Walnut
Marrón Nogal

Availability of cabinet finishes may vary depending on market area. / La disponibilidad de los acabados de la caja puede variar en función de área de mercado.

DIGITAL PIANOS

CA Series

The Concert Artist range are quite simply the finest digital pianos available, with our rich, 88 year heritage in crafting fine acoustic instruments inspiring a selection of digital pianos that deliver nuance, artistry, and an exceptional musical experience.

Los pianos Concert Artist son los mejores pianos digitales disponibles, gracias a nuestra experiencia de 88 años en fabricar instrumentos acústicos excepcionales, resultando en una selección que ofrece matiz, maestría y una experiencia musical excepcional.

NEW



CA97

- GRAND FEEL ACTION II
- IVORY EBONY TOUCH
- 3 Sensor
- LET-OFF
- Counter weight
- 88 key HI-XL
- MAX POLY 256
- 80 SOUNDS
- 128x64 LCD DISPLAY
- LESSON
- USB TO HOST
- USB TO DEVICE
- MP3/WAV
- AMP SIM
- SOUND BOARD
- SHS

NEW



CA67

- GRAND FEEL ACTION II
- IVORY EBONY TOUCH
- 3 Sensor
- LET-OFF
- Counter weight
- 88 key HI-XL
- MAX POLY 256
- 60 SOUNDS
- 128x64 LCD DISPLAY
- LESSON
- USB TO HOST
- USB TO DEVICE
- MP3/WAV
- AMP SIM
- SHS

NEW



CA17

- GRAND FEEL ACTION II
- IVORY EBONY TOUCH
- 3 Sensor
- LET-OFF
- Counter weight
- 88 key HI-XL
- MAX POLY 192
- 19 SOUNDS
- LESSON
- VOICE ASSIST
- SOUND PREVIEW

NEW



CA17

- GRAND FEEL ACTION II
- IVORY EBONY TOUCH
- 3 Sensor
- LET-OFF
- Counter weight
- 88 key HI-XL
- MAX POLY 192
- 19 SOUNDS
- LESSON
- VOICE ASSIST
- SOUND PREVIEW

NEW



Soundboard Speaker

DIGITAL PIANOS

CN Series

An affordable range of high specification instruments, the popular CN Series feature Progressive Harmonic Imaging™ 88-key sampling technology and grade-weighted keyboard actions, establishing a new standard in digital piano value and performance.

Una gama asequible de instrumentos de altas prestaciones. La popular serie CN dispone de Progressive Harmonic Imaging™ tecnología de muestreo de 88 teclas y acción de teclado graduada por peso, establece un estándar nuevo tanto en el valor como en el rendimiento de los pianos digitales.

NEW



CN35

- RHAction
- Ivory Touch
- 3 Sensor
- LET-OFF
- Counter weight
- 88 key PHI
- MAX POLY 256
- 324 SOUNDS
- LCD DISPLAY
- LESSON
- USB TO HOST
- USB TO DEVICE
- MP3/WAV
- AMP SIM
- GENERAL MIDI 2

NEW



CN25

- RHAction
- Ivory Touch
- 3 Sensor
- LET-OFF
- Counter weight
- 88 key PHI
- MAX POLY 192
- 19 SOUNDS
- LESSON
- VOICE ASSIST
- SOUND PREVIEW

GRAND FEEL II

The new Grand Feel II (GFII) keyboard action utilised by the latest Concert Artist instruments features the longest wooden keys and key-pivot available, with triple-sensor detection, graded counterweights, and luxurious Ivory+Ebony Touch key surfaces.

El nuevo mecanismo del teclado Grand Feel II (GFII) utilizado en las últimas funciones de los instrumentos de la serie Concert Artist con las teclas de madera y el pivote más largo, con triple detección de sensor, contrapesos graduados, y superficie de teclas de Ivory+Ebony Touch.

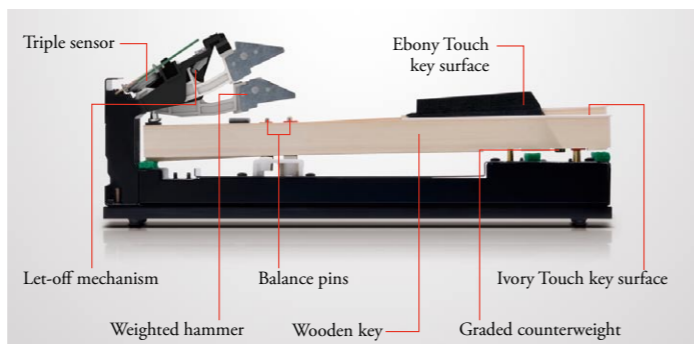

Responsive Hammer III

The new Responsive Hammer III (RHIII) keyboard action utilised by the CN series instruments features grade-weighted hammers, triple-sensor key detection, counterweights and a rigid design that ensures a natural piano playing experience.

El mecanismo Responsive Hammer III (RHIII) utilizado en los instrumentos de las series CN con macillos de peso graduado, triple sensor de detección de teclas, contrapesos y un diseño resistente que asegura una experiencia muy natural en la interpretación pianística.

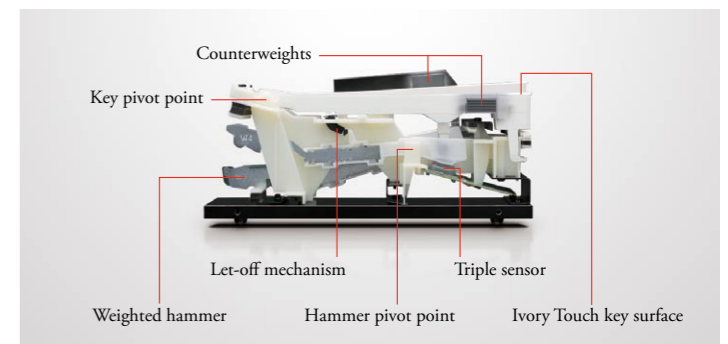

LUXURY DIGITAL PIANOS

Classic Series

The Classic Series range of premium digital pianos combine Kawai's superior keyboard action and sound technology with finely crafted polished ebony cabinets, resulting in a collection of stunning instruments that play as beautifully as they look.

El abanico de pianos digitales Premium de la serie Classic combina el mecanismo de teclado superior de Kawai y la tecnología de sonido, en un mueble de ébano pulido ofreciendo una colección de impresionantes instrumentos con un sonido tan perfecto como su apariencia.



CS10

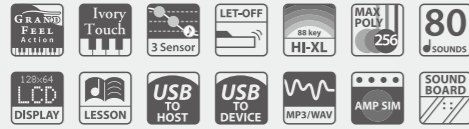

Soundboard Speaker



CS7

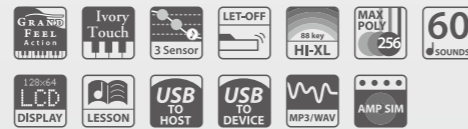

CS4



SPECIFICATIONS

	CA97	CA67
Keyboard	88 wooden keys with Ivory and Ebony Touch key surfaces	
Action	Grand Feel II with Let-off, Triple sensor, and Counterweights	
Sound Source	Harmonic Imaging™ XL (HI-XL), 88-key piano sampling	
Internal Sounds	80 voices	60 voices
Polyphony	max. 256 notes	
Display	128 x 64 pixel LCD with backlight	
Reverb	Types: Room, Lounge, Small Hall, Concert Hall, Live Hall, Cathedral Parameters: Reverb Depth, Reverb Time	
Effects	Ping/Mono/Triple Delay, Chorus, Classic Chorus, Ensemble, Tremolo, Classic Tremolo, Vibrato Tremolo, Auto Pan [+AMP], Classic Auto Pan, Phaser [+AMP], Classic Phaser, Rotary. Combination effects x 3	
Recorder	10 song, 2 track recorder – 90,000 notes	
USB Functions	Play & Record MP3/WAV/MID, Load & Save Internal Song/Registration/User Memory, Save SMF Song, Rename File, Delete File, Format USB, Convert Song to Audio, Overdub Audio	
Demo Songs	39 songs + 42/29 Piano Music pieces *	37 songs + 42/29 Piano Music pieces *
Concert Magic	176 songs	
Lesson Function	Finger exercises + Alfred, Burgmüller, Czerny, Beyer, Bach, Chopin lesson books	
Virtual Technician	Voicing (incl. User Voicing) Damper Resonance/Noise, String Resonance, Undamped String Resonance, Cabinet Resonance, Key-off Effect (incl. Key-off Release), Fall-back Noise, Hammer Delay, Topboard, Decay Time, Soft Pedal Depth, User Touch Curve, Temperament, Key of Temperament, Stretch Tuning, Tuning, User Tuning, User Key Volume, Half-Pedal Adjust, Minimum Touch	
Other Features	Dual/Split/Four Hands, Balance Adjust, Key/Song Transpose, Tone Control (incl. User EQ), Speaker Volume, Audio Recorder Gain, Line In Level, Wall EQ ¹ , Damper Hold, LCD Contrast, Startup Setting, Factory Reset, Metronome (with 100 rhythms), Registrations, SHS Mode, Phones Volume, Lower Octave Shift, Lower Pedal On/Off, Layer Octave Shift, Layer Dynamics, MIDI Channel, Send PGM#, Local Control, Transmit PGM#, Multi-timbral Mode, Channel Mute, Auto Power Off	
Jacks	MIDI (IN/OUT), USB (to Host, to Device), LINE IN (Stereo), LINE IN Level Adjust, LINE OUT (L/MONO, R), LINE OUT Level Adjust, Headphones x 2	
Pedals	Damper (with Half-Pedal support), Sostenuto, Soft. Grand Feel Pedal System	
Speakers	7 cm x 4 + 1.4 cm x 2 + 132 cm x 53 cm Soundboard Speaker	13 cm x 2 + (8 x 12) cm x 2 + 5 cm x 2
Output Power	45 W x 2 + 45 W transducer	50 W x 2
Dimensions	146 (W) x 47 (D) x 93 (H) cm	146 (W) x 46 (D) x 93 (H) cm
Weight	85.0 kg	76.0 kg

	CA17	CN35	CN25
Keyboard	88 wooden keys with Ivory Touch key surfaces	88 weighted keys with Ivory Touch key surfaces	
Action	RM3 Grand II action with Let-Off and Triple sensor	Responsive Hammer III with Let-off, Triple sensor, and Counterweights	
Sound Source	Harmonic Imaging XL™ (HI-XL), 88-key piano sampling	Progressive Harmonic Imaging™ (PHI), 88-key piano sampling	
Internal Sounds	19 voices	324 voices + 12 drum kits (GM2 compatible)	19 voices
Polyphony	max. 192 notes	max. 256 notes	max. 192 notes
Display	-	16 x 2 characters LCD	-
Reverb	Room, Lounge, Small Hall, Concert Hall, Live Hall, Cathedral	Room, Lounge, Small Hall, Concert Hall, Live Hall, Cathedral	
Effects	Preset	13 types	Preset
Recorder	3 song, 1 track recorder – 10,000 notes	3 song, 2 track recorder – 90,000 notes	3 song, 1 track recorder – 10,000 notes
USB Functions	-	Play & Record MP3/WAV/MID, Convert Song to Audio, Load & Save Song/Registration, Save SMF Song, Rename, Delete, Format	-
Demo Songs	19 songs + 42/29 Piano Music pieces *	31 songs	19 songs
Concert Magic	88 songs	88 songs	40 songs
Lesson Function	Alfred, Beyer, Burgmüller and Czerny lesson books	Alfred, Beyer, Burgmüller and Czerny lesson books	
Virtual Technician	Voicing, Damper Resonance, Damper Noise, String Resonance, Key-off Effect, Fall-back Noise, Stretch Tuning	Voicing, String Resonance, Damper Resonance, Damper Noise, Key-off Effect, (incl. Key-off Release), Fall-back Noise, Stretch Tuning, Hammer Delay, Topboard, Decay Time, S.Pedal Depth... (=CA95/CA65)	Voicing, String Resonance, Damper Resonance, Damper Noise, Key-off Effect, (incl. Key-off Release), Fall-back Noise, Stretch Tuning
Other Features	Sound Preview, Vocal Assist, Touch Curve, Dual, Brilliance, Transpose, Tuning, Metronome, Startup Setting, Factory Reset, Auto Power Off, MIDI functions	Touch Curve, Temperament, Dual/Split/Four Hands, Balance Slider, Key/Song Transpose, Tuning, Metronome (with 100 rhythms), Startup Setting, Factory Reset, Auto Power Off, MIDI functions	Sound Preview, Vocal Assist, Touch Curve, Dual, Brilliance, Transpose, Tuning, Metronome, Startup Setting, Factory Reset, Auto Power Off, MIDI functions
Jacks	MIDI (IN/OUT), USB to Host, Headphones x 2	MIDI (IN/OUT), USB (to Host, to Device), LINE IN (L/MONO, R), LINE OUT (L/MONO, R), Headphones x 2	MIDI (IN/OUT), USB to Host, Headphones x 2
Pedals	Damper (with Half-Pedal support), Sostenuto, Soft. Grand Feel Pedal System	Damper (with Half-Pedal support), Sostenuto, Soft. Grand Feel Pedal System	
Speakers	13 cm x 2 + 5 cm x 2	13 cm x 2 + (8 x 12 cm) x 2	12 cm x 2
Output Power	20 W x 2	20 W x 2	
Dimensions	137 (W) x 46 (D) x 90 (H) cm	138 (W) x 47 (D) x 89 (H) cm	136 (W) x 40 (D) x 86 (H) cm
Weight	59.0 kg	55.0 kg	42.0 kg

	CS10	CS7	CS4
Keyboard	88 wooden keys with Ivory Touch key surfaces		
Action	Grand Feel with Let-off and Triple sensor		
Sound Source	Harmonic Imaging™ XL (HI-XL), 88-key piano sampling		
Internal Sounds	80 voices	60 voices	15 voices
Polyphony	max. 256 notes		
Display	128 x 64 pixel LCD with backlight		
Reverb	Types: Room, Lounge, Small Hall, Concert Hall, Live Hall, Cathedral Parameters: Reverb Depth, Reverb Time		
Effects	Stereo Delay, Ping Delay, Triple Delay, Chorus, Classic Chorus, Tremolo, Classic Tremolo, Auto Pan, Classic Auto Pan... (=CA95/CA65)		
Recorder	10 song, 2 track recorder - 90,000 notes		
USB Functions	Play & Record MP3/WAV/MID, Load & Save Internal Song/Registration/User Memory, Save SMF Song... (=CA95/CA65)		
Demo Songs	37 songs + 42/29 Piano Music pieces *	34 songs + 42/29 Piano Music pieces *	15 songs + 42/29 Piano Music pieces *
Concert Magic	176 songs		
Lesson Function	Finger exercises + Alfred or Burgmüller, Czerny, Beyer, and Bach lesson books *		
Virtual Technician	Voicing, Damper Resonance/Noise, String Resonance, Key-off Effect (incl. Key-off Release), Fall-back Noise, Hammer Delay, Topboard, Decay Time, Soft Pedal Depth, User Touch Curve, Temperament, Key of Temperament, Stretch Tuning, Tuning, User Tuning, User Key Volume, Half-Pedal Adjust, Minimum Touch		Damper Resonance, Key-off Release
Other Features	Dual/Split/Four Hands, Balance Adjust, Key/Song Transpose, Tone Control (incl. User EQ), Speaker/Phones/Line Out Volume, Audio Recorder Gain, Line In Level ¹ , Wall EQ ¹ , Damper Hold, LCD Contrast, User Memory, Factory Reset, Metronome (with 100 rhythms), Registrations, Lower Octave Shift, Lower Pedal On/Off, Layer Octave Shift, Layer Dynamics, MIDI settings (=CA95/CA65)		Damper Resonance, Touch Curve, Four Hands Mode, Transpose, Tuning, Metronome, Brilliance, MIDI functions
Jacks	MIDI (IN/OUT), USB (to Host, to Device), LINE IN (L/MONO, R), LINE IN Level Adjust, LINE OUT (L/MONO, R), Headphones x 2		
Pedals	Damper (with Half-Pedal support), Sostenuto, Soft. Grand Feel Pedal System		
Speakers	7 cm x 4 + 1.4 cm x 2 + 132 cm x 53 cm Soundboard Speaker	13 cm x 2 + 5 cm x 2	12 cm x 2 + 5 cm x 2
Output Power	45 W x 2 + 45 W transducer	50 W x 2	20 W x 2
Dimensions	151 (W) x 54 (D) x 105 (H) cm	145 (W) x 47 (D) x 95 (H) cm	142 (W) x 43 (D) x 91 (H) cm
Weight	102.0 kg	80.0 kg	54.0 kg

* depending on market area / En función de área de mercado.

¹ CA97 only. / solo CA97.

DIGITAL STAGE PIANOS

MP Series

Regarded by music industry insiders as quintessential stage pianos, the MP Series offer unrivalled touch, superb sound, and excellent live performance control – fulfilling the requirements of professional musicians, whether in the studio or on tour.

Considerados por la industria musical como pianos de escenario ideales, la serie MP ofrece una pulsación sin par, sonido espléndido, y excelente control de interpretación en directo – cumpliendo las exigencias profesionales, tanto en estudio como de gira.



MP 11



MP 7



VIRTUAL PIANO CONTROLLER

VPC1

The VPC1 is a professional MIDI keyboard controller developed especially for use with virtual piano software, delivering a new standard in performance and expression.

El VPC1 es un teclado controlador MIDI profesional desarrollado especialmente para su uso con el software de piano virtual, ofreciendo un nuevo estándar en el rendimiento y la expresión.

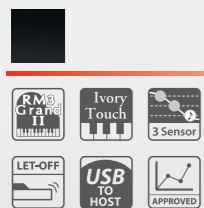

PORTABLE DIGITAL PIANO

ES Series

Compact and portable, the multi-purpose ES7 and ES100 instruments feature realistic keyboard actions, powerful speakers, and a selection of excellent sounds suitable for various musical opportunities – wherever the venue, and whatever the occasion.

Compactos y portátiles, los multiusos ES7 y ES100 disponen del último mecanismo de teclado, sistema de potentes altavoces, y una selección de sonidos excelentes, para dar una gama apropiada para todos los estilos musicales – sin importar el lugar o la ocasión.



ES7

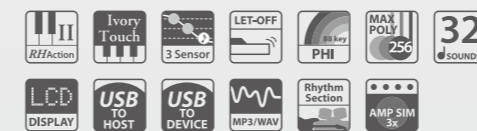

Additional HM-4 Designer Stand & F-301 Triple Pedal accessories also available.
Adicionales accesorios el stand de diseño HM-4 y el pedal triple F-301 también disponibles.



ES100



Additional HML-1 Designer Stand & F-350 Triple Pedal accessories also available.
Adicionales accesorios el stand de diseño HML-1 y el pedal triple F-350 también disponibles.

COMPACT DIGITAL PIANOS

CL Series

The Compact Line range of digital pianos provide an excellent introduction to Kawai quality, and are ideally suited to pianists that require a modern, slimline instrument without wishing to sacrifice touch authenticity or tonal quality.

La gama de pianos digitales Compact Line es una introducción excelente a la calidad de Kawai, y es idónea para pianistas que quieren un instrumento moderno y estilizado sin querer sacrificar la autenticidad de la pulsación o la calidad del tono.



CL36



CL26



SPECIFICATIONS

	CL36	CL26
Keyboard	88 weighted keys with Ivory Touch key surfaces	88 weighted keys
Action	Responsive Hammer action	Advanced Hammer Action IV-F
Sound Source	Progressive Harmonic Imaging™ (PHI), 88-key piano sampling	Harmonic Imaging™, 88-key piano sampling
Internal Sounds	15 voices	8 voices
Polyphony		max. 96 notes
Recorder	3 song, 1 track recorder - 15,000 notes	-
Demo Songs	15 songs	8 songs
Concert Magic		40 songs
Lesson Function	Alfred or Burgmüller and Czerny lesson books, depending on market area	-
Other Features	Damper Effect, Touch Curve, Dual, Reverb Four Hands Mode, Transpose, Tuning, Metronome, Auto Power Off	Touch Curve, Dual, Reverb Transpose, Tuning, Metronome, Auto Power Off
Jacks	MIDI (IN/OUT), Headphones x 2, Pedal	MIDI (IN/OUT), Headphones x 2, Pedal
Pedals	Damper (with Half-Pedal support), Sostenuto, Soft	Damper (with Half-Pedal support) (F-10H unit)
Speakers		(12 x 8 cm) x 2
Output Power	15 W x 2	15 W x 2
Dimensions	137 (W) x 29.5 (D) x 77 (H) cm	128 (W) x 27 (D) x 77 (H) cm
Weight	36.5 kg	28.5 kg

SPECIFICATIONS

	MP11	MP7
Keyboard	88 wooden keys with Ivory Touch key surfaces	88 weighted keys with Ivory Touch key surfaces
Action	Grand Feel with Let-off and Triple sensor	Responsive Hammer II with Let-off and Triple sensor
Sound Source	Harmonic Imaging™ XL (HI-XL), 88-key piano sampling	
Sections / Zones	Sections: PIANO, E.PIANO, SUB, MIDI (4 x external Zones)	Zones: 4 x internal, 4 x external (MIDI)
Internal Sounds	40 voices (12 x PIANO, 12 x E.PIANO, 16 x SUB)	256 voices (8 categories x 8 sounds x 4 variations) + Tonewheel Simulator
Polyphony	max. 256 notes	
Display	128 x 64 pixel LCD with backlight	
Effects	6 Reverb types, 129 Effects types, 5 Amp Simulator types (E.PIANO section only)	6 Reverb types, 129 (MAIN) / 23 (SUB) Effects types, 5 Amp Simulator types (MAIN zone only)
USB Functions	Play MP3/WAV/MID, Record MP3/WAV/MID, Overdub, Convert Song to Audio, Audio Recorder Gain, SMF Direct Play (MP7 only) Load/Save: One Sound, One Setup, SMF, All Sound, All Backup	
Controls	Pitch Bend, Modulation, Master Volume, Line In Volume, Section Volume (x 3), Assignable Control Knobs (x 4), MMC Transport	Pitch Bend, Modulation, Master Volume, Line In Volume, Zone Volume (x 4), Assignable Control Knobs (x 4), MMC Transport
Virtual Technician	Voicing, Damper Resonance, String Resonance, Key-off Effect, Damper Noise, Hammer Delay, Topboard, Fall Back Noise, Brilliance (MP11 only), Key-off Noise, Key-off Delay, Key Click Level (MP7 only), Wheel Noise Level (MP7 only), User Touch Curve, Temperament, Stretch Tuning, Stereo Width	
Other Features	Transpose, Tuning, Metronome (with 100 rhythms), ADSR Tone Modify, Zone Key Range, SETUPS, 10 song recorder, Line In Recorder	
Jacks	MIDI (IN/OUT/THRU), USB (to Host, to Device), LINE IN (L/MONO, R), LINE OUT (L/MONO, R), XLR OUT (L, R) with Ground Lift switch, Headphones x 1, Damper / Sostenuto Pedal, Soft Pedal, Expression Pedal, Foot Switch	MIDI (IN/OUT/THRU), USB (to Host, to Device), LINE IN (L/MONO, R), LINE OUT (L/MONO, R), Headphones x 1, Damper Pedal, Damper / Sostenuto Pedal, Soft (FSW) Pedal, Expression Pedal
Pedals	Damper (with Half-Pedal support), Sostenuto, Soft (F-30 unit)	Damper (with Half-Pedal support) (F-10H unit)
Dimensions	138 (W) x 45 (D) x 19 (H) cm	135 (W) x 34 (D) x 17 (H) cm
Weight	32.5 kg	21.0 kg

<http://www.kawaiipc.com>

	ES7	
Keyboard	88 weighted keys with Ivory Touch key surfaces	Metronome 1/4, 2/4, 3/4, 4/4, 5/4, 3/8, 6/8, 7/8, 9/8, 12/8 (Volume/Tempo adjustable)
Action	Responsive Hammer II with Let-off and Triple sensor	Virtual Technician Voicing, String/Damper Resonance, Damper Noise, Fall-back Noise, Key-off Effect (incl. Key-off Release), Hammer Delay, User Touch Curve, Temperament, Key of Temperament, Stretch Tuning, Tuning
Sound Source	Progressive Harmonic Imaging™, 88-key piano sampling	Other Features Dual/Split/Four Hands, Balance Adjust, Key/Song Transpose, Equaliser (incl. User EQ), Wall EQ, Speaker/Phones/Line Out Volume, Audio Recorder Gain, Damper Hold, User Memory, Factory Reset, Lower Octave Shift, Lower Pedal On/Off, Layer Octave Shift, Layer Dynamics, Dual Balance, MIDI Channel, Send PGM#, Local Control, Transmit PGM#, Multi-timbral Mode, Channel Mute, Auto Power Off, Speakers On/Off
Internal Sounds	32 voices	Jacks MIDI (IN/OUT), USB (to Host, to Device), LINE IN (STEREO), LINE OUT (L/MONO, R), Headphones x 2, Pedal
Polyphony	max. 256 notes	Pedals Damper (with Half-Pedal support), Sostenuto and Soft with optional F-301H
Display	16 x 2 characters LCD	Speakers (8 x 12 cm) x 2
Reverb	Room, Lounge, Small Hall, Concert Hall, Live Hall, Cathedral	Output Power 15 W x 2
Effects	Stereo Delay, Ping Delay, Triple Delay, Chorus, Classic Chorus, Tremolo, Classic Tremolo, Auto Pan, Classic Auto Pan, Phaser, Rotary. Combination effects x 4	Dimensions 136 (W) x 36 (D) x 15 (H) cm
Amp Simulator	S.Case I, S.Case II, L.Cabinet	Weight 22.0 kg
Recorder	10 song, 2 track recorder - 90,000 notes	
USB Functions	Play MP3/WAV/MID, Record MP3/WAV. Load & Save Internal Song/Registration, Save SMF Song, Rename File, Delete File, Format USB, Convert Song to Audio	
Demo Songs	Main demo song, Rhythm Section demo song, 25 sound demo songs	
Accompaniment	Rhythm Section: 100 styles (x 2 variations), 4-part accompaniment, 100 preset chord sequences, One-Finger Ad-lib, ACC Mode	

	ES100
Keyboard	88 weighted keys
Action	Advanced Hammer Action IV-F
Sound Source	Harmonic Imaging™, 88-key piano sampling
Internal Sounds	19 voices
Polyphony	max. 192 notes
Recorder	3 song, 1 track recorder - 15,000 notes
Demo Songs	12 songs
Lesson Function	Alfred and Burgmüller lesson books
Other Features	Damper Resonance, Voicing, Fall-back Noise, Damper Noise, Touch Curve, Dual, Split, Reverb, Transpose, Tuning, Temperament, Metronome (with 100 rhythms), Speakers On/Off, Auto Power Off
Jacks	MIDI (IN/OUT), Headphones x 2, Pedal
Pedals	F-10H unit: Damper(w/H.P. sup.) F-350 unit: Damper (w/H.P. sup.), Sostenuto, Soft
Speakers	(12 x 8 cm) x 2 17 W x 2
Dimensions	131 (W) x 29 (D) x 14.5 (H) cm
Weight	15.0 kg

	VPC1
Keyboard	88 wooden keys with Ivory Touch key surfaces
Action	RM3 Grand II with Let-off and Triple sensor
Preset Touch Curves	Normal, Ivory, Pianoteq, Galaxy, Alicia's Keys
Internal Memories	5 memories (for use with VPC Editor software)
Jacks	MIDI (IN/OUT), USB to Host ('B' type) Damper/Sostenuto pedal, Soft pedal,
Pedals	Damper (with Half-Pedal support), Sostenuto, Soft (F-30 unit)
Power Consumption	USB bus powered (1.0 W), AC adaptor powered (3.0 W)
Dimensions	138 (W) x 43 (D) x 19 (H) cm
Weight	29.5 kg

<http://www.kawaiipc.com>

DIGITAL PIANO FINISHES

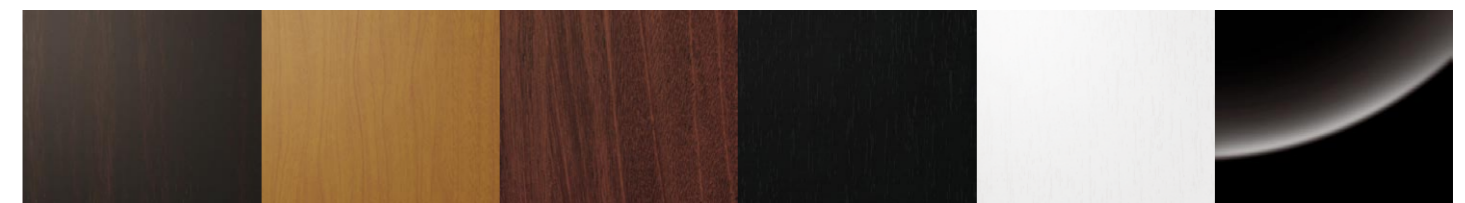

Premium Rosewood
Palisandro Premium

Premium Cherry
Cerezo Premium

Premium Mahogany
Caoba Premium

Premium Satin Black
Negro Satinado Premium

Premium Satin White
Blanco Satinado Premium

Ebony Polish
Ebano Pulido

Availability of cabinet finishes may vary depending on market area. / La disponibilidad de los acabados de la caja puede variar en función de área d e mercado.

